



OPERATION AND MAINTENANCE MANUAL

DOCUMENT TITLE: Operation and Maintenance Manual 250W Subsea USB System
PROJECT: 600128
DOCUMENT NUMBER: 600128-TD-0007
REV: 07
NUMBER OF PAGES: 16

DATE: 22.09.20
CLIENT: N/A
CLIENT CONTACT: N/A





OBJECTIVE

The objective of this document is to cover all aspects required for safe use, operation and maintenance of the Blue Logic 250W Subsea-USB System. Relevant technical aspects for information and familiarization shall be covered as well as required technical data.

ABSTRACT

The Blue Logic 250W Subsea-USB system is based on the WPC/ Blue Logic inductive technology for transfer of electrical power and communication subsea. The 250W connector system is part of the complete "Subsea-USB" system covering power range from 50W to 2000W with Ethernet communication speeds up to 80Mbit.

In general, each Subsea-USB system consists of a Primary and a Secondary side installed in a Male and Female subsea housing. The power is transferred from the Primary side to the Secondary side, whilst communication is in both directions. Upon request, two-way power transfer is available on some connectors.

The Male and Female Subsea-USB Connectors can be configured in the following alternatives:

1. Manually operated by hand
2. ROV operated
3. Bulkhead installation
4. Combined with hydraulic connector thus allowing for electrical power, communication and hydraulic connections to be made up using the same connector assembly.

The Blue Logic/WPC Subsea-USB System transforms 100V~250 VAC input voltage to a 24VDC from primary to secondary side. The system can also be delivered with other voltage settings thus allowing for optimization of voltage and power on different types of subsea systems and for different consumers. For example, different secondary side connectors can be configured to extract different voltages or from the same primary side. This means that different types of consumers (with different voltage or power requirements) can be connected to the same primary side.

REVISION CHANGE/RECORD

REV	REASON FOR REVISION/ DESCRIPTION OF CHANGES
01	Issued for Use
02	Added info, IP address config.
04	Updated 150W → 250W
05	Info regarding LED indicators added
06	Updated LED Indicator function
07	Updated with info from WPC's datasheets

TABLE OF CONTENT

1.	INTRODUCTION	4
1.1.	SAFETY.....	4
1.2.	DOCUMENT USE.....	4
1.3.	ABBREVIATIONS.....	4
2.	TECHNICAL DESCRIPTION	5
2.1.	SYSTEM OVERVIEW	5
2.2.	MATING INTERFACES.....	6
2.2.1.	Main Features.....	8
2.2.2.	Primary-Secondary Designation	8
2.3.	TECHNICAL DATA.....	9
2.4.	PIN CONFIGURATION.....	10
2.5.	IP ADDRESS CONFIGURATION.....	12
2.6.	LED INDICATOR LIGHTS	13
2.7.	250W SUBSEA-USB COMBINED WITH HYDRAULIC CONNECTORS	14
3.	OPERATION	15
3.1.	PRE DIVE CHECK LIST	15
3.2.	CONNECTION.....	15
3.3.	DISCONNECTION.....	16
3.4.	POST DIVE CHECK LIST	16



1. INTRODUCTION

The Blue Logic inductive connector system is designed for subsea connection and transfer of electrical power and communication. Due to the plug and play functionality of the wireless connectors, Blue Logic has given them the brand name Subsea-USB.

In addition, the inductive connectors can be mounted onto hydraulic connectors thus allowing for simultaneous connection of electrical power, communication and hydraulic power.

The Subsea-USB Connectors are intelligent units that automatically detects when it is mated and immediately enables power and communication transfer.

In general, a Subsea-USB connector consist of a mechanical housing which houses required electronic PCB's and coils for transmission of power and communication.

1.1. SAFETY



WARNING: The equipment to which this manual applies must only be used for the purpose for which it was designed. Improper use or maintenance may cause damage to the equipment and/or injury to personnel. All users must be familiar with the contents of the appropriate manuals before attempting to install, operate, maintain or in any other way work on the equipment.

Blue Logic AS disclaims any responsibility for damage or injury caused by improper installation, use or maintenance of the equipment

1.2. DOCUMENT USE

This document shall be used as general information for all aspects related to safe use, installation, removal, maintenance and storage of the 250W Subsea-USB Connectors

1.3. ABBREVIATIONS

IP	Internet Protocol
PCD	Pitch Circle Diameter
PFC	Power Factor Controller
ROV	Remotely Operated Vehicle
VAC	Volt Alternating Current
VDC	Volt Directional Current
WPC	Wireless Power & Communication AS



2. TECHNICAL DESCRIPTION

2.1. SYSTEM OVERVIEW

The Blue Logic 250W Subsea-USB System can be delivered with a variety of mechanical configurations and interfaces as illustrated in below figure. In addition, electrical alternatives with respect to power, voltage, current and communication setup can be delivered upon request. Following paragraphs describe the standard configurations available as standard products with competitive prices and delivery times.

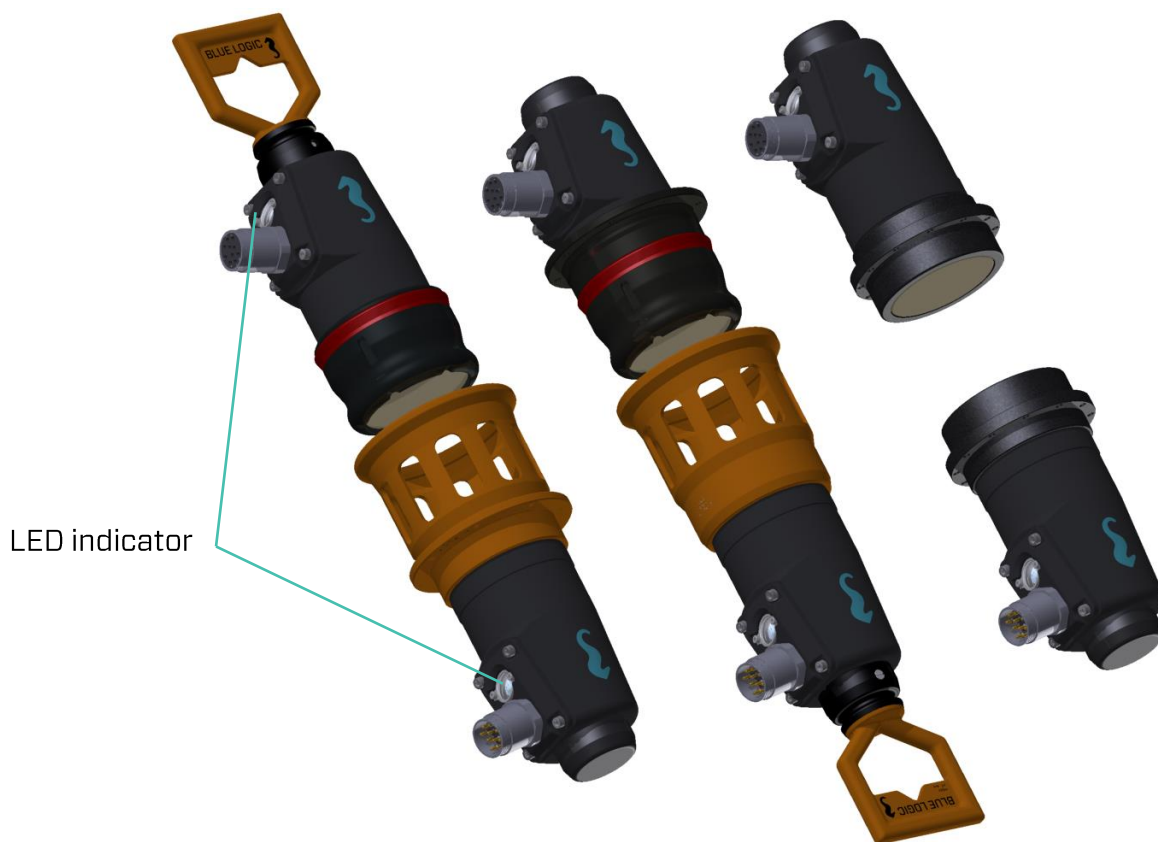

Figure 1 Alternative configurations of the Blue Logic Subsea-USB System



2.2. MATING INTERFACES

The 250W Subsea-USB connector is a ROV friendly and compact inductive connector system designed primarily for intervention purposes suitable for all types of ROV tools where electrical power and electronic communication is required.

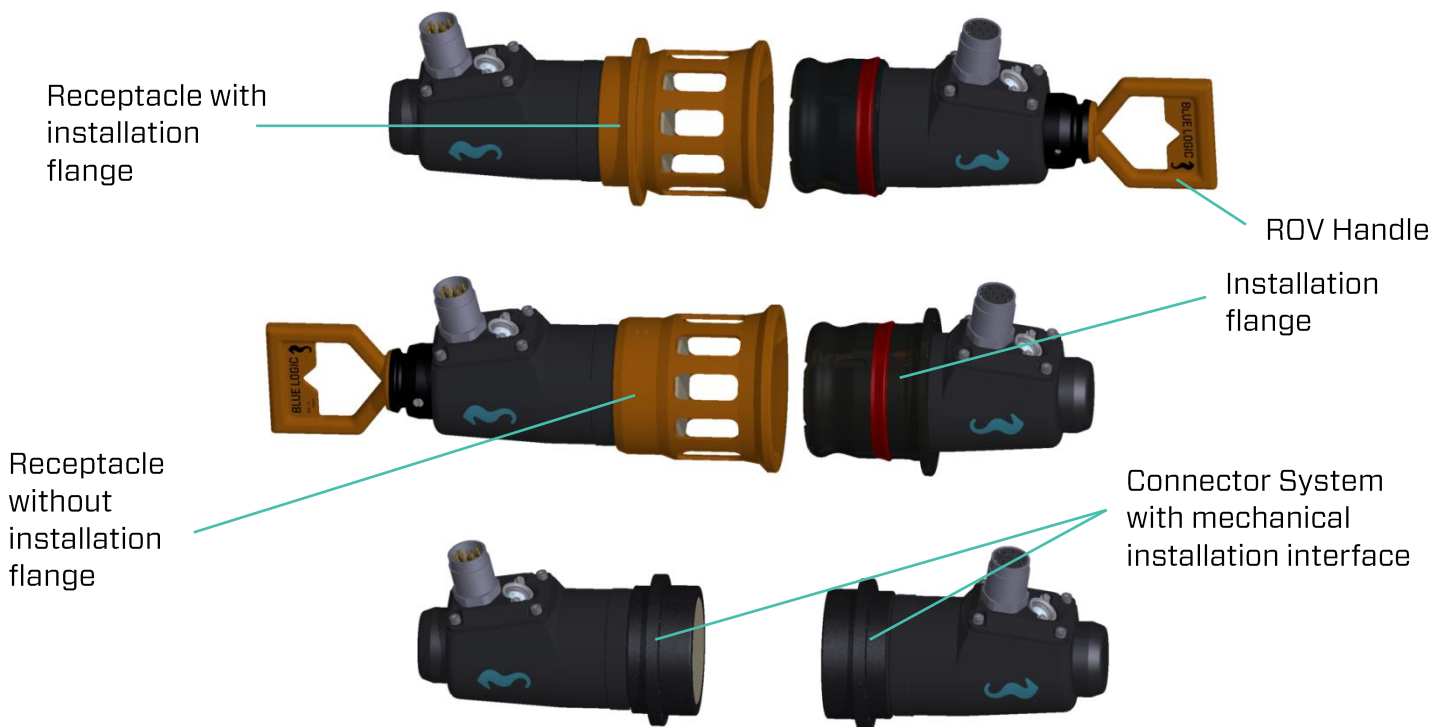

Figure 2

The connector system is available with a mechanical installation interface or with a guiding system that locks the primary and secondary unit together. The guiding system is equipped with a friction lock solution specially designed for ROV use.

The guide system can be delivered with or without a mechanical flange for panel installation, or ROV handle as shown on above figure.



Figure 3 Typical Male Stab



Figure 4 Typical Female Receptacle

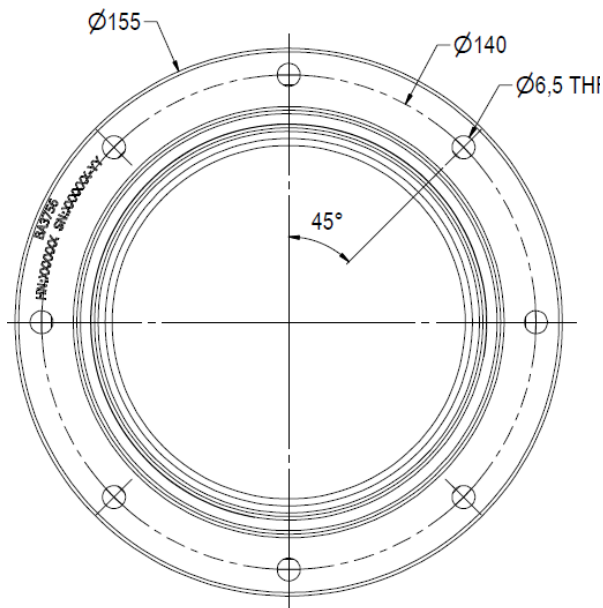

Figure 5 Installation flange

Installation flange interface is 8 x Ø6.5 on PCD 140mm as shown on above figure.

2.2.1. Main Features

- DC to DC Wireless power transfer
- High efficiency - up to 93%
- Up to 250W load
- Inrush limitation
- Over temperature protection
- Overload protection
- Short circuit protection
- RS232 or RS485
- Ethernet 100BASE-TX
- Optional LED Indicators

2.2.2. Primary-Secondary Designation

The primary-secondary designation refers to the transfer direction of electrical power. The primary inductive coupler act as “sender” of power, with the secondary inductive coupler as “receiver” of the power.

Some units have the capability of switching the power transfer direction, i.e. a unit can act as a primary or as a secondary unit depending on the required power direction.



OPERATION AND MAINTENANCE MANUAL

2.3. TECHNICAL DATA

Overall dimensions	See Assembly Drawing
Design Water Depth	3000m
Ambient temperature	-10 - +45 °C
Max operation @250W in 20°C air	30 min
Max operation @250W in 20°C water	∞
Overheat protection	55°C, inside canister
Input Voltage Primary Side	100-250 VAC *
	145-350 VDC*
Output Voltage	24 VDC *
Output Power	250 W
Output current	10,5A
Power draw no load, Axial distance=0mm	22W
Efficiency 24VDC 250W	82%
Efficiency 325VDC 250W	86%
Start-up time power & RS232/RS485	10 sec
Start-up time Ethernet	90 sec
Start-up time RS232	10 sec
Start-up time RS485	10 sec
Communication Protocol	RS232 or RS485 + Ethernet**
Communication speed RS232	1,2 - 230 kbps Full Duplex
Communication speed RS485	1,2 - 230 kbps Half Duplex
Communication Speed Ethernet	80 Mbps
Electrical Connector, Primary Side	BCR24 10M
Electrical Connector, Secondary Side	BCR2410F

* Other voltage and power configurations are available upon request to meet project or client specific requirements.

** Connector system can be configured for RS485 upon request.



OPERATION AND MAINTENANCE MANUAL

2.4. PIN CONFIGURATION

The Standard 250W Subsea-USB Connectors is equipped with Subcon BCR24 10-Pin Connectors. Other connectors are however available upon request as special deliveries.

Primary side Subsea-USB Connectors are equipped with Male Subcon Connectors while Secondary Side are equipped with female connectors.

Table 1

Primary Side with RS232		Primary Side with RS485	
Connector: Subcon BCR2410M		Connector: Subcon BCR2410M	
Pin #	Signal	Pin #	Signal
Pin 1	100-250VAC	Pin 1	100-250VAC
Pin 2	100-250VAC	Pin 2	100-250VAC
Pin 3	CHASSIS	Pin 3	CHASSIS
Pin 4	RS232RX*	Pin 4	RS485A(+)
Pin 5	RS232TX**	Pin 5	RS485B(-)
Pin 6	RS232GND	Pin 6	RS 485 GND
Pin 7	TX_p	Pin 7	TX_p
Pin 8	TX_n	Pin 8	TX_n
Pin 9	RX_p	Pin 9	RX_p
Pin 10	RX_n	Pin 10	RX_n

*Data going into unit.

** Data going out of unit.

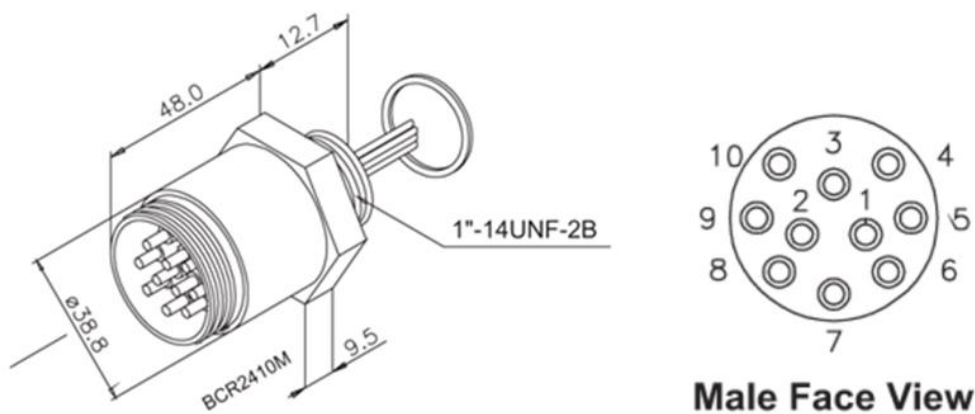

Figure 6 BCR2410M Bulkhead Connector



OPERATION AND MAINTENANCE MANUAL

Table 2

Secondary Side with RS232		Secondary Side with RS485	
Connector: Subcon BCR2410F		Connector: Subcon BCR2410F	
Pin #	Signal	Pin #	Signal
Pin 1	+24VDC	Pin 1	+24VDC
Pin 2	GND	Pin 2	GND
Pin 3	CHASSIS	Pin 3	CHASSIS
Pin 4	RS232RX**	Pin 4	RS485A(+)
Pin 5	RS232TX***	Pin 5	RS485B(-)
Pin 6	RS232GND	Pin 6	RS 485 GND
Pin 7	TX_p	Pin 7	TX_p
Pin 8	TX_n	Pin 8	TX_n
Pin 9	RX_p	Pin 9	RX_p
Pin 10	RX_n	Pin 10	RX_n

**Data going into unit.

*** Data going out of unit

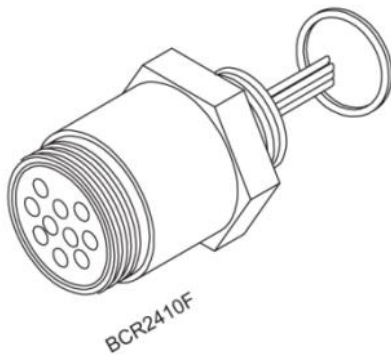

Figure 7 - BCR2410F Bulkhead Connector

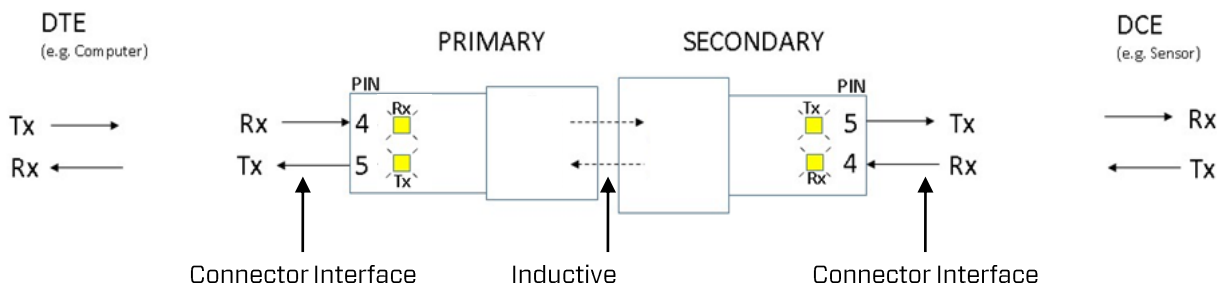

Figure 8 - RS COM Dataflow

2.5. IP ADDRESS CONFIGURATION

All Subsea-USB systems are delivered with a fixed IP address. The used addresses are listed in table below. It is recommended to avoid having other equipment in the same network using the same IP address. Other IP configurations of the Subsea-USB system are however available upon request as special deliveries. The IP addresses of the Subsea-USB system do not affect the transmission of data and it is not required that the IP address of the Subsea-USB system lies within the IP range of the network.

Table 3

Unit	IP Address
Primary side	192.168.1.253
Secondary side	192.168.1.254



OPERATION AND MAINTENANCE MANUAL

2.6. LED INDICATOR LIGHTS

The 250W Subsea-SB have LED indicator lights visible to ROV for showing status of the Subsea-USB connector during use and connecting.



Figure 9 - LED Indicator

Name	LED Status	Description
POW (Primary side)	On	Start-up voltage limit passed*
	Blinking	Alarm state
POW (Secondary side)	On	Output voltage activated
	Blinking	Alarm state
ETH	On	Ethernet connection made
	Blinking	Data transmitted or received
RX	On	System ready to receive data
	Blinking	System receiving data
TX	On	Primary and Secondary side connected System ready to send data
	Blinking	System sending data

* Turned on "Pow" LED Primary side does not verify that the input voltage is within the specified range.



2.7. 250W SUBSEA-USB COMBINED WITH HYDRAULIC CONNECTORS

Blue Logic Subsea-USB systems can be combined with hydraulic connectors to form a combined multifunctional connectors system allowing for both hydraulic and electrical connection in the same interface. Installation brackets are available for most types of Blue Logic delivered stab systems, both Hot Stabs and Valve stabs. Installation of the Subsea-USB units onto hydraulic stab is performed in accordance with the dedicated assembly drawings. Mating/ de-mating of the combined system shall be performed in accordance with the manual for the hydraulic connector system (Hot Stab or Valve Stab).

Note that Valve Stab connectors are rotation dependent and are not correct docked before the indicator pin is activated correctly.



Figure 10 Subsea-USB installed on a 3-Port Valve Stab receptacle



Figure 11 Subsea-USB installed on a 3-Port Male Valve Stab

3. OPERATION

3.1. PRE DIVE CHECK LIST

No.	Description	Chk/Verified
01	Perform a function test by connecting primary and secondary side. <ul style="list-style-type: none"> - Test communication - Test Power transfer 	
02	Perform a visual inspection of primary side connector <ul style="list-style-type: none"> - Housing - Seals - Coil Surface - Connector 	
03	Perform a visual inspection of secondary side connector <ul style="list-style-type: none"> - Housing - Seals - Coil Surface - Connector 	
04	If the Subsea-USB Connector is connected to a hydraulic connector, ensure that the mechanical bracket is undamaged, and that the primary and secondary side is connected parallel when the hydraulic connector is fully mated.	

3.2. CONNECTION

No.	Description	Chk/Verified
01	Inspect the stab/receptacles to be mated by ROV visually. Verify that mating surfaces are clean	
02	By use of the ROV manipulator gently mate the male and female (primary/secondary) connectors.	
03	Verify that the connectors are fully mated and that cables are undamaged	
04	Verify that power and communication is transferred between the connectors	

3.3. DISCONNECTION

No.	Description	Chk/Verified
01	Inspect the male/female stab system	
02	Inspect cables and connectors	
03	Gently grab the connector through the ROV handle and pull the stab slowly out from receptacle	
04	Inspect stab, receptacle, cables and connectors	

3.4. POST DIVE CHECK LIST

No.	Description	Chk/Verified
01	Recover system to deck	
02	Inspect all components and parts. Special attention to the following: <ul style="list-style-type: none"> - Housing - Surface treatment - Corrosion - Seal - Coil surfaces - Cables - Penetrators - Connectors - Mechanical interfaces 	
03	Flush all components and parts thoroughly with fresh water	
04	Connect System and perform a full system check	